



AQUA ILLI.

The world's smartest touch tap.

Innovative design, cutting-edge technology, and premium aesthetics. The highest performing tap on the market today.



FEATURES.

- Patented boiler design gives high volumes of boiling water
- Perfect water flow with zero splash
- Removable dispense nozzle for improved hygiene
- Plumbed-to-waste flush-fitting drip tray
- Safe dispense with a touch padlock feature
- Installed in modular form to fit into the tightest of spaces
- Pre-set fill volumes for any vessel and free flow options available
- Equality Act compliant controls available
- Touch or touchless modules available



AVAILABLE FINISHES

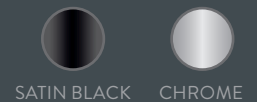

SATIN BLACK CHROME

CAPACITY



BOILING

PER HOUR

High

up to **45** litres or **180** cups

Ultra high

up to **90** litres or **180** flask/tea pots



CHILLED / SPARKLING / AMBIENT

PER HOUR

up to **45** litres or **180** glasses

up to **45** litres or **240+** glasses

*Based on the following measurements: 1 cup/glass = 250ml & 1 flask/tea pot = 500ml

TALK TO US

London showroom: 1 New Street, London, EC2M 4TP

www.aqualibra.com | 0800 080 6696 | hello@aqualibra.com

PRE-INSTALLATION REQUIREMENTS



1

WATER.

No. 1 x Potable cold mains water supply terminating in a 15mm Ballofix isolation valve.

2

POWER.

No. 3 x 220 - 240V ac 50Hz
Single switched 13A power sockets.

3

WASTE.

No. 1 x 40mm upstand trapped waste supply.

Please visit www.aqualibra.com/ventilation for all ventilation options.

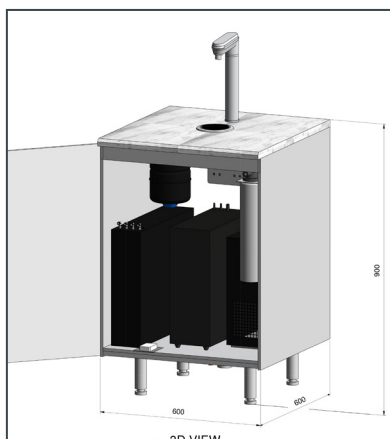

Aqua illi - BCA Full Installation

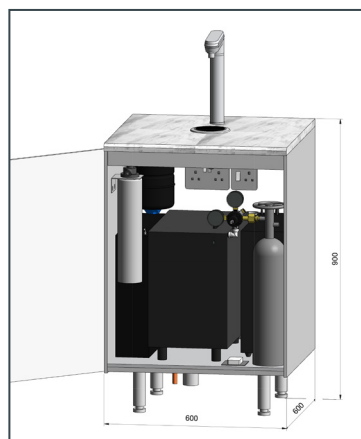

Aqua illi - BCS Full Installation



SINGER CAPITAL MARKETS

Investing into sustainable hydration technology.



CHALLENGE

Singer Capital Markets were passionate about creating an office break area that was reflective of the company's cultures, values, and social impact. Collaboration with like-minded businesses that could support and deliver a modern and progressive environment was essential.

Aqua Libra Co were the perfect choice when looking for market leading hydration technologies that would provide their employees with sustainable, high-performing hydration stations to fulfil the fast-paced demands of the team, whilst also creating a haven to build a truly collaborative workplace.

Their sustainability agenda to reduce waste as an office was a major factor when choosing the perfect hydration partner that would support the principles of a circular economy.

SOLUTION

Located across 2 different refreshment zone within 3 floors, the Aqua illi, black satin, three-in-one touch tap's innovative design, cutting-edge technology, and premium aesthetics make this tap one of the highest performing taps on the market today, providing the perfect dispense combination for such a high performing office environment.



OKTRA.

Transforming working lives (and hydration).



CHALLENGE

Oktra is an award-winning office design company with branches in London, Stafford, and Guildford. Dedicated to prioritising sustainable solutions, this company's mission is to strengthen the relationship between people and their environment, drive wellbeing and green initiatives within the built environment and work communities, and to create spaces that inspire people to do amazing things.

We've worked with Oktra on many commercial projects, but on this occasion, they were looking for a high-performance hydration solution for their very own office in Farringdon. The Oktra team wanted their new water-dispense system to be energy efficient, space saving, and a good match for their office décor.

SOLUTION

The Aqua Libra Co team installed two Aqua illi Taps in stylish Satin Black finish, each dispensing boiling, chilled, and sparkling water. At one of the hydration stations, the tap features a 60mm extension to enable bottle filling.

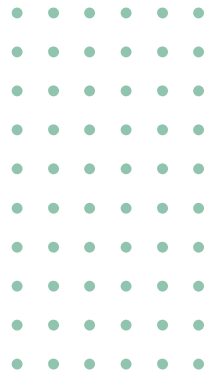



THANK YOU.

 0800 080 6696

 HELLO@AQUALIBRA.COM

 WWW.AQUALIBRA.COM

©2023 Aqua Libra Co. All rights reserved. Continuing improvements may necessitate change specifications without notice.

